

# POINT

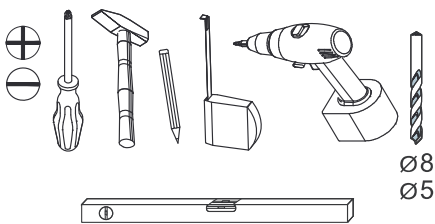
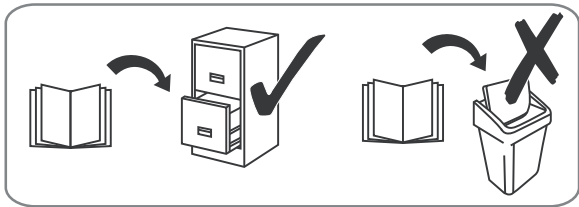
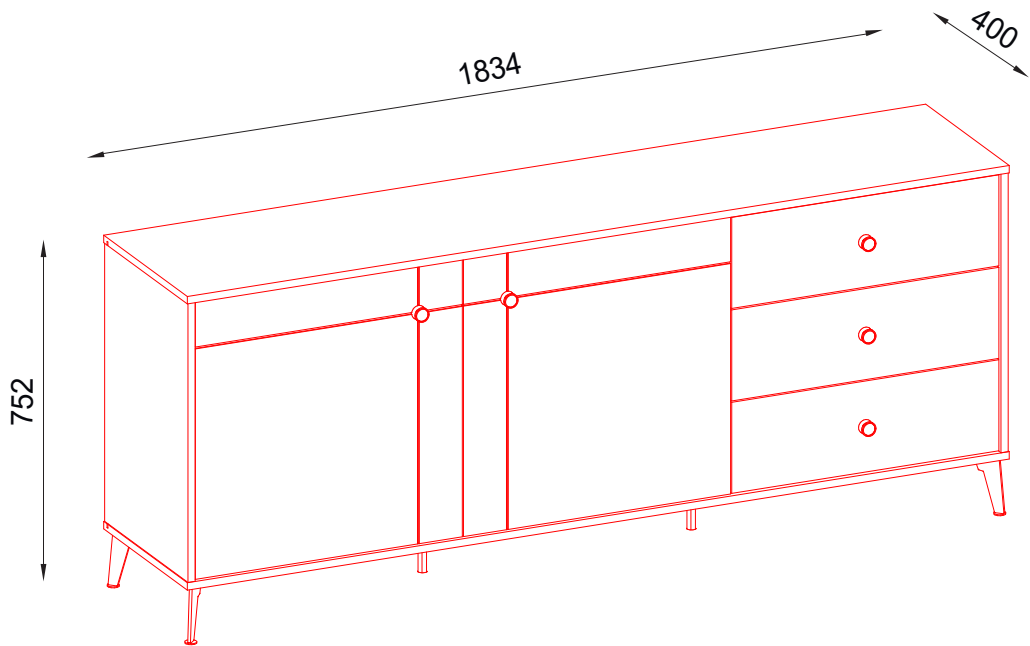

festziehen / tighten / Затягнете /  
serrer / stringere / utåhnut / vasttrekken /  
zategnuti / strångere / zwiázac / zacisnaç  
szorosan meghúzni / pevne dotiahnut /  
trdno pritegniti / затянуть / dra át

eindrücken / press in / enfoncer / wcisnaç  
ribattere / zatlačit / Вкарайте / indrukken  
benyomni / stlačit / vtisniti / tryck in  
introducere prin apăsare / вдавить

ausmessen / measure / mesurer /  
misurare / orpmelen / izmeriti / miara /  
kimérni / izmeriti / măsurare / измерить  
změřit / Измерете / mät upp / zmierzyc

drücken / press / presser / stisknout /  
Натиснете / vtisniti / nasinac / drukken /  
pritisnuti / nacisnac / pritisniti / нажать /  
(meg)nyomni / apăsare / tryck fast / nacisnaç

einschlagen / hammer in / beverni / slå in  
frapper au marteau / infossare / Zabit /  
zarazit / Набийте / zabiti / wbić  
introducere prin bătaie / забить / zatout

Drehen - wenden / przekrećić - odwrócić /  
Keren - omdraaien / Girare - Ruotare /  
Okrenuti - ubnuti / Retourner - renverser /  
Turn over - turn around / Otocte - obratle /  
Завъртете - обърнете / Obrnite list /  
Întoarceți - rotiți / Vrid runt - vänd /  
прокрутить - повернуть / otočit - obrátit  
elforgalni - megfordítani

# POINT

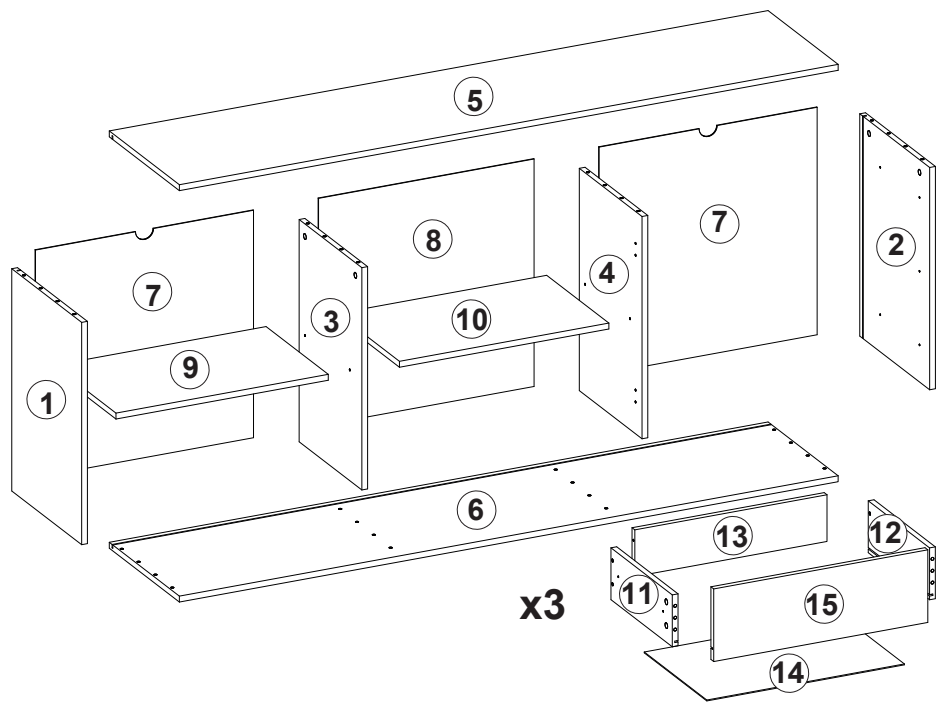



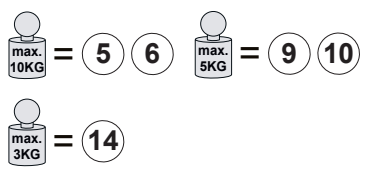
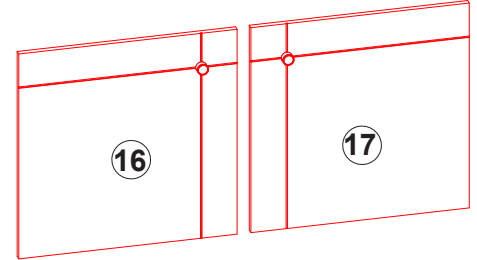





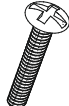

A	B (mm)		C	D
1	600	399	16	x1 2/2
2	600	399	16	x1 2/2
3	600	358	16	x1 1/2
4	600	358	16	x1 2/2
5	1834	400	16	x1 2/2
6	1834	400	16	x1 2/2
7	614	607	2,5	x2 1/2
8	614	600	2,5	x1 1/2
9	591	355	16	x1 2/2
10	583	355	16	x1 2/2
11	350	140	16	x3 1/2
12	350	140	16	x3 1/2
13	551	126	16	x3 1/2
14	567	357	2,5	x3 1/2
15	596	196	16	x1 1/2
16	596	596	16	x1 1/2
17	596	596	16	x1 1/2
B1				1/2



# POINT

## B1

<b>A0</b>  Ø8x30 <b>x22</b>	<b>C1</b>  16 mm <b>x20</b>	<b>Z</b>  4mm <b>x1</b>	<b>B1</b>  Ø6,4x50 <b>x20</b>	<b>D11</b>  3,5x16 <b>x30</b>	<b>L14</b>  <b>x5</b>	<b>D19</b>  4x16 <b>x5</b>	<b>C2</b>  L-44 <b>x20</b>	<b>C07</b>  Ø20 <b>x4</b>	<b>C08</b>  Ø20 <b>x16</b>
<b>J16</b>  <b>x2</b>	<b>J8</b>  <b>x2</b>	<b>N12</b>  L-350 <b>x3</b>	<b>N14</b>  L=75x20x15mm <b>x2</b>	<b>E2</b>  8x50 <b>x2</b>	<b>M1</b>  <b>x16</b>	<b>D14</b>  3x15 <b>x16</b>	<b>N1</b>  <b>x8</b>	<b>T10</b>  <b>x4</b>	<b>T12</b>  <b>x2</b>
<b>D17</b>  3,5x16 <b>x43</b>									

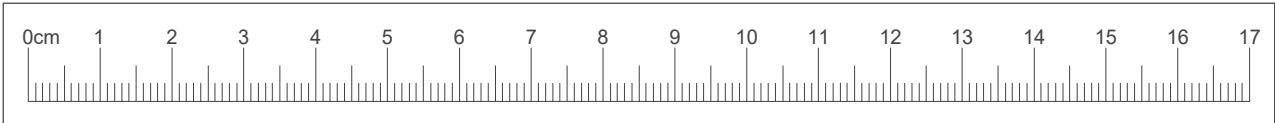

# 1

<b>A0</b>  Ø8x30 <b>x6</b>	<b>C1</b>  16 mm <b>x12</b>	<b>Z</b>  4mm <b>x1</b>	<b>B1</b>  Ø6,4x50 <b>x12</b>	<b>C08</b>  Ø20 <b>x12</b>	<b>L14</b>  <b>x3</b>	<b>D19</b>  4x16 <b>x3</b>	<b>C2</b>  L-44 <b>x12</b>
-------------------------------------	--------------------------------------	----------------------------------	--	-------------------------------------	-----------------------------	-------------------------------------	-------------------------------------

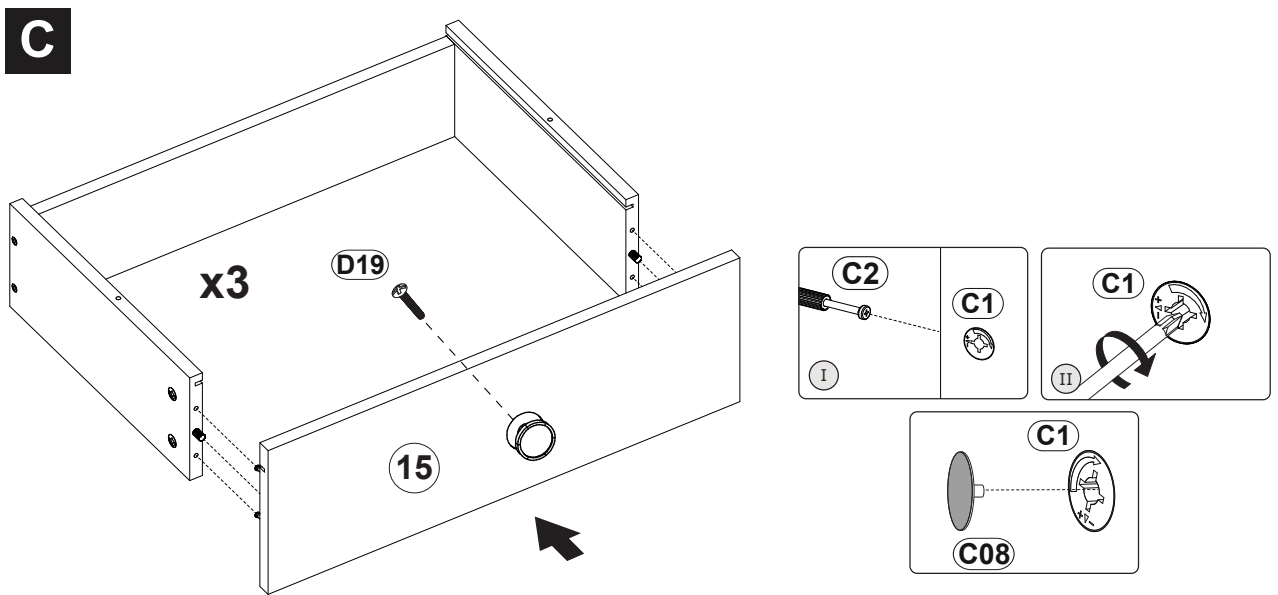
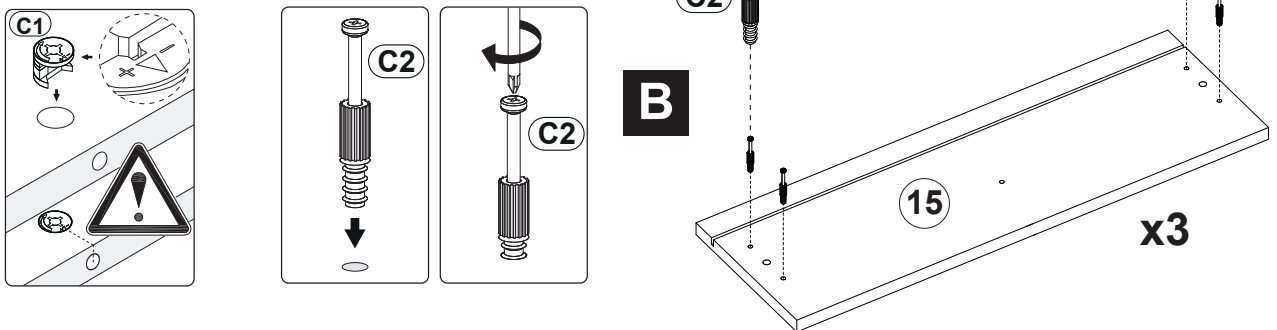
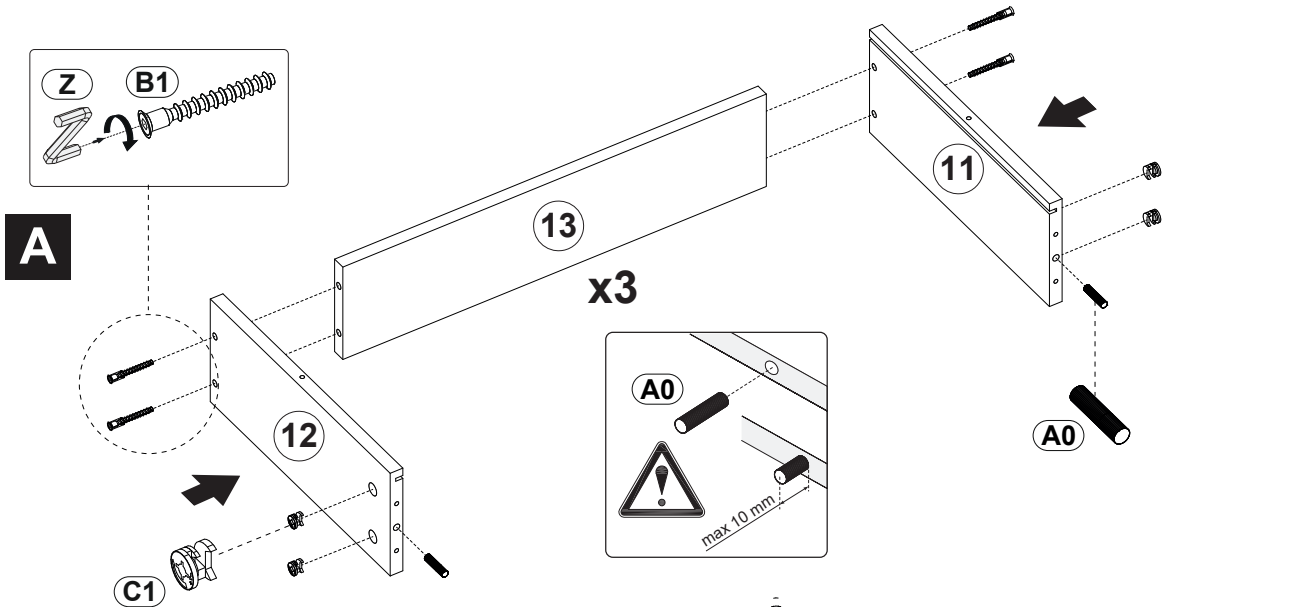

2

D

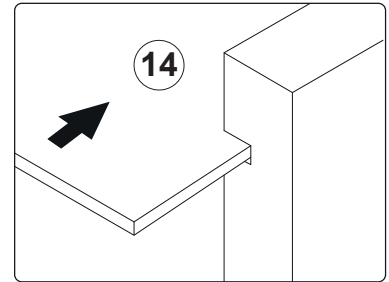
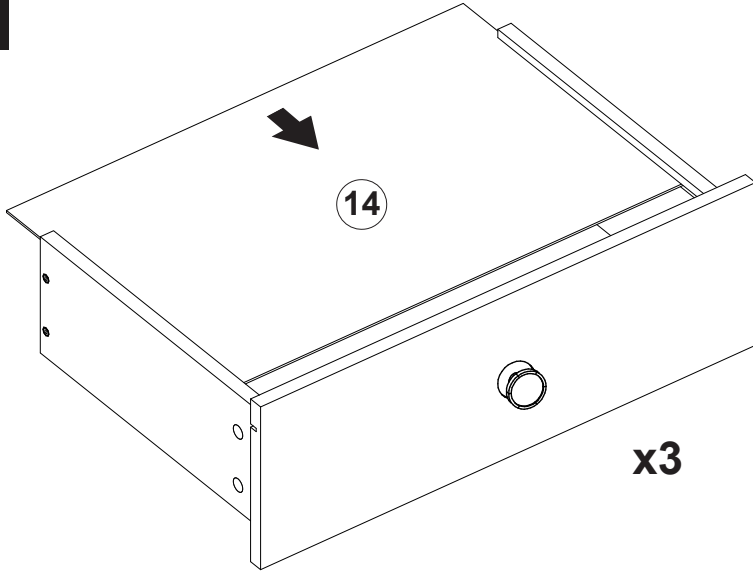

D17



3.5x16



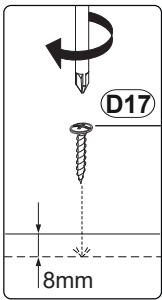

x15

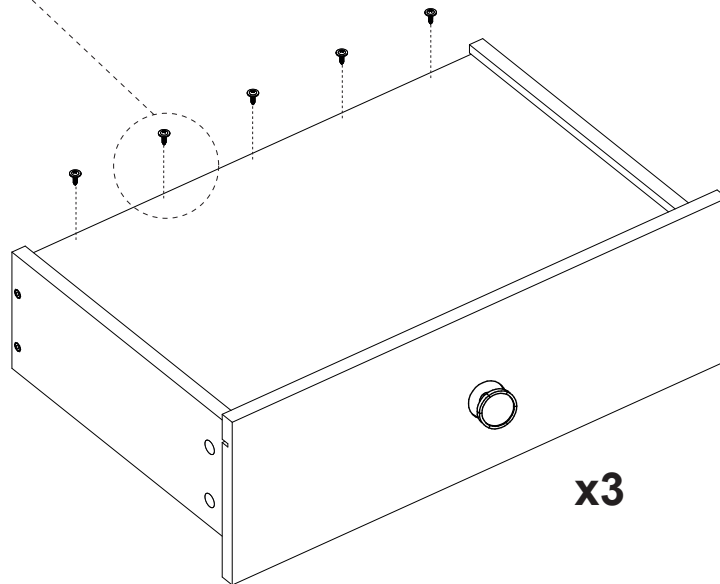

E

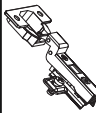

# 3



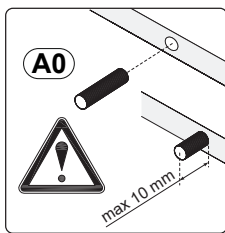
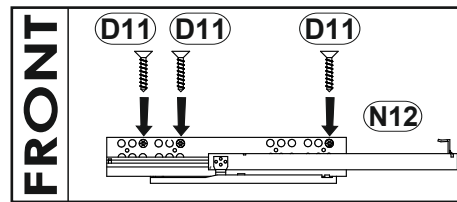
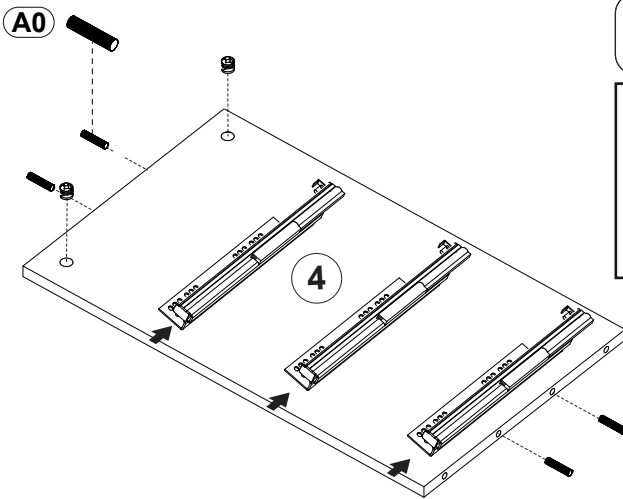
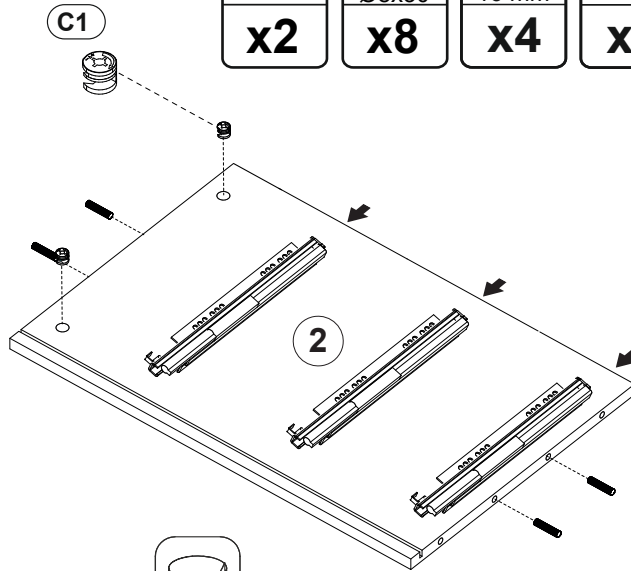
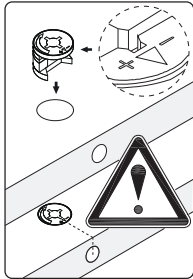

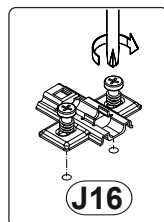
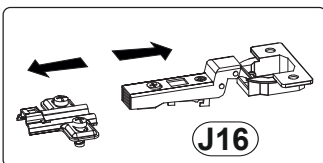
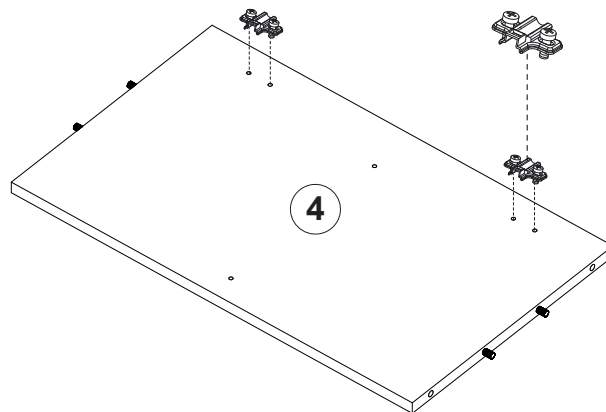

<b>J16</b>  <b>x2</b>	<b>A0</b>  Ø8x30 <b>x8</b>	<b>C1</b>  16 mm <b>x4</b>	<b>N12</b>  L-350 <b>x6</b>	<b>D11</b>  3,5x15 <b>x18</b>
--	--	--	---	---



180°

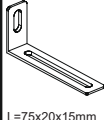

# 4

<b>C2</b>	<b>J8</b>	<b>A0</b>	<b>C1</b>	<b>N14</b>	<b>D11</b>
 L-44		 Ø8x30	 16 mm	 L=75x20x15mm	 3,5x15
<b>x8</b>	<b>x2</b>	<b>x8</b>	<b>x4</b>	<b>x2</b>	<b>x4</b>

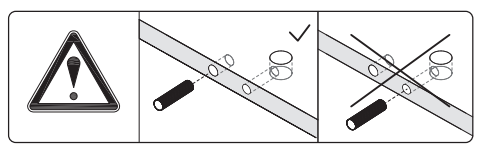
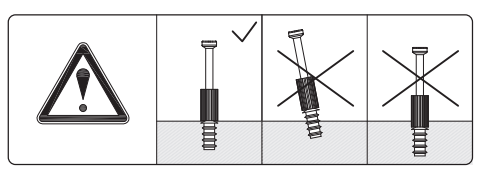
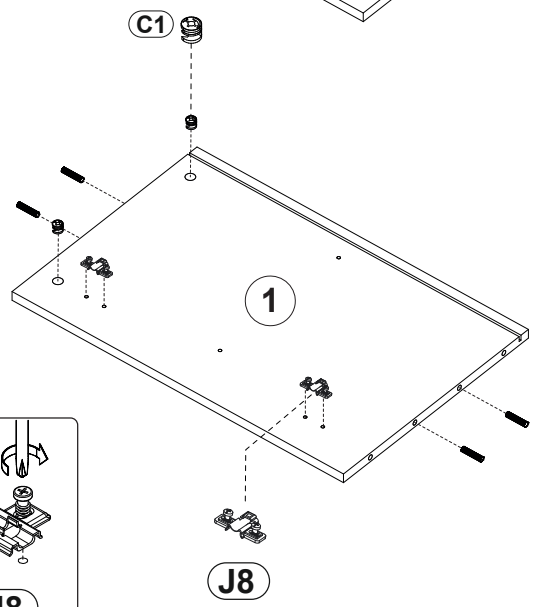
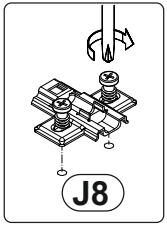
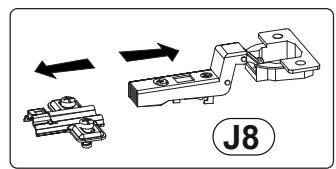
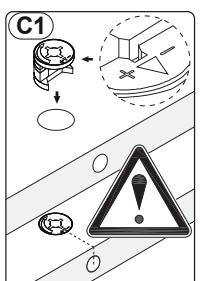
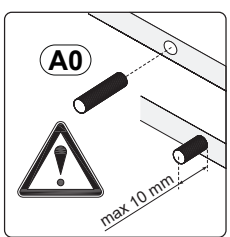
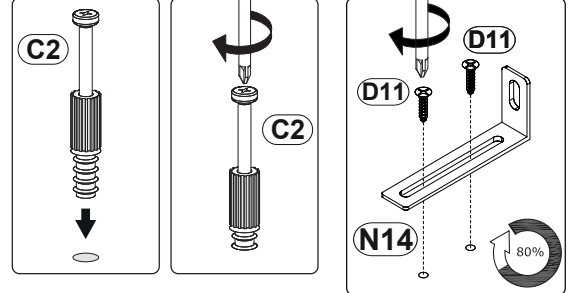
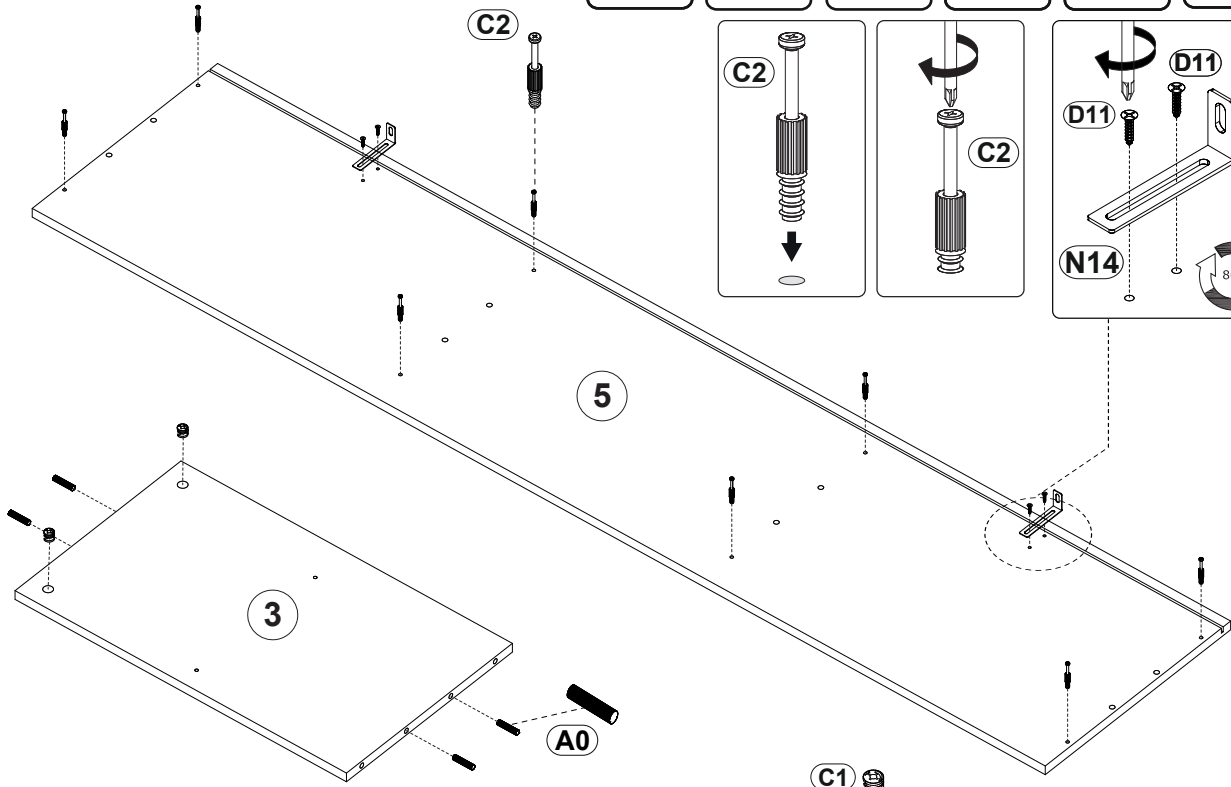

5

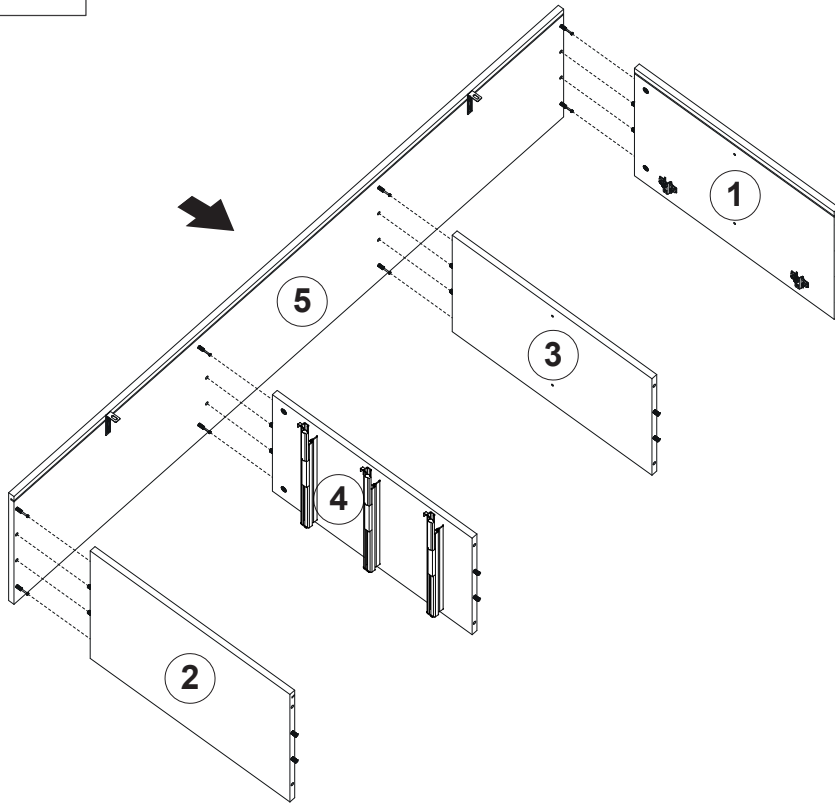

<b>C07</b>	<b>C08</b>
Ø20	Ø20
<b>x4</b>	<b>x4</b>

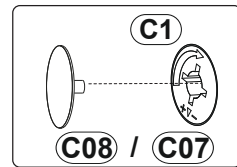
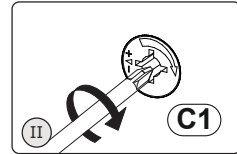
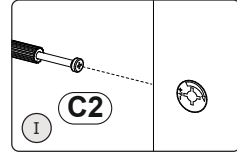

6

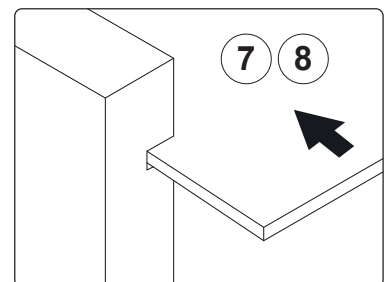
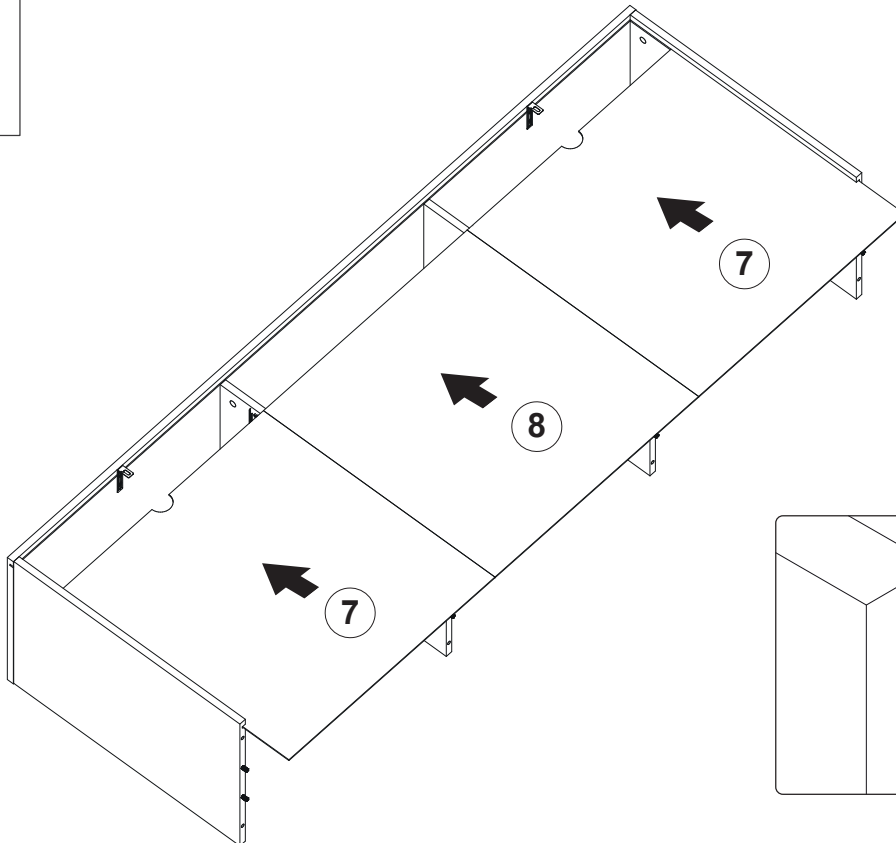

# 7

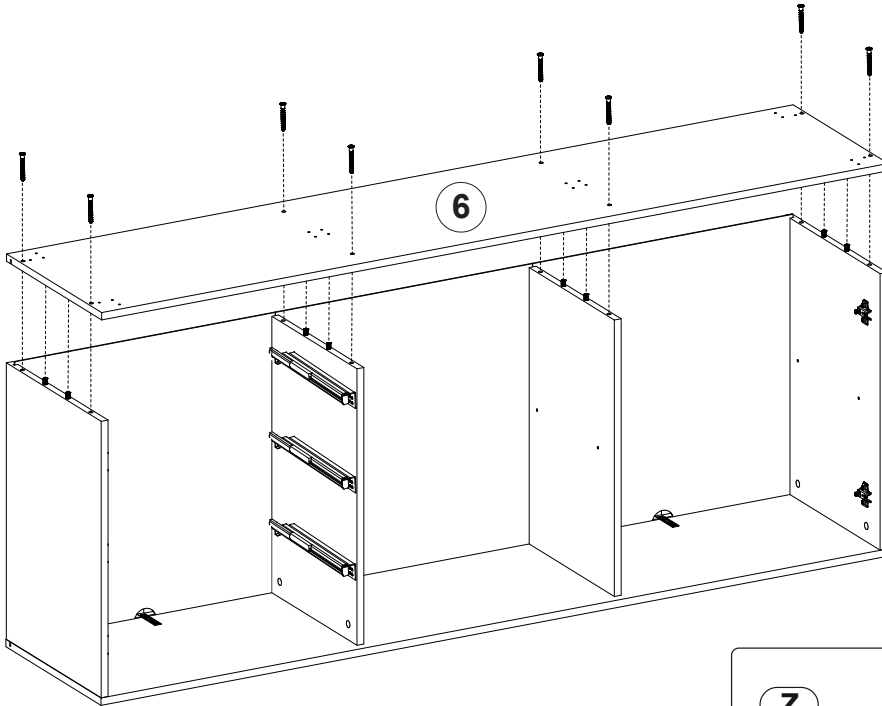
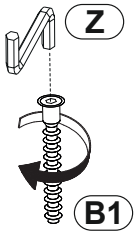

<b>Z</b>	<b>B1</b>
4mm	Ø6,4x50
<b>x1</b>	<b>x8</b>

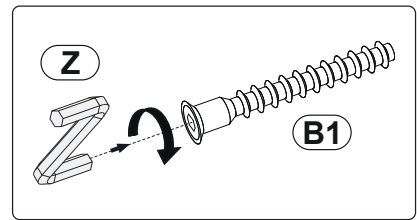

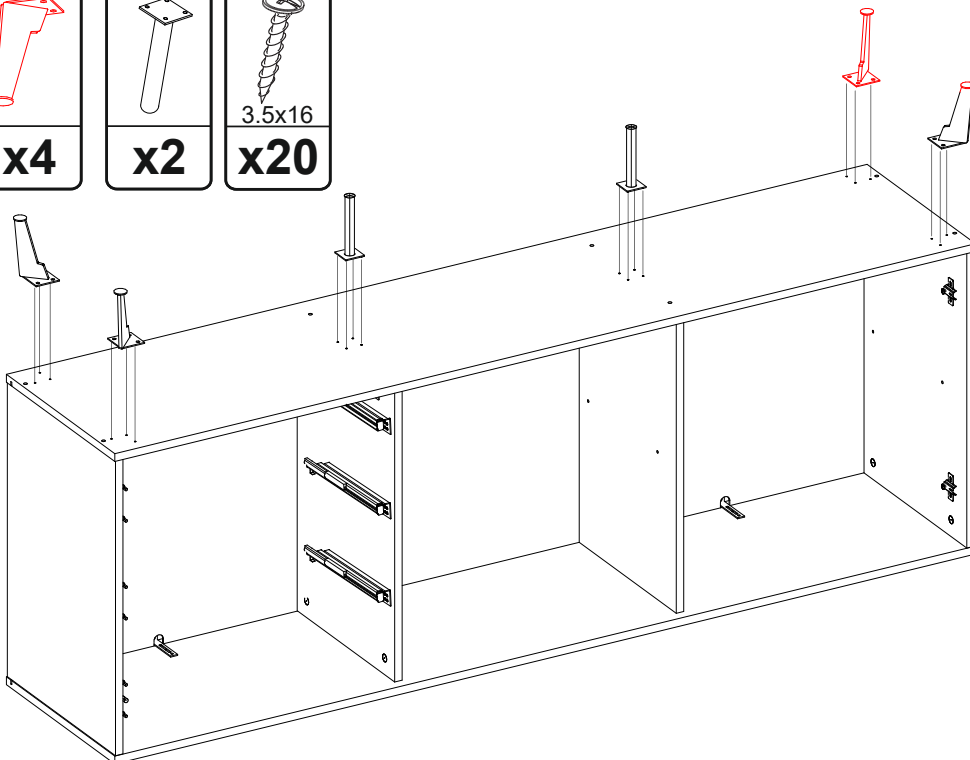

# 8

<b>T10</b>	<b>T12</b>	<b>D17</b>
x4	x2	x20



9

<b>M1</b>	<b>D17</b>	<b>D14</b>
		
	3.5x16	3x15
<b>x16</b>	<b>x8</b>	<b>x16</b>

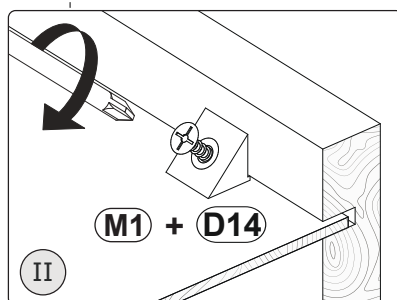
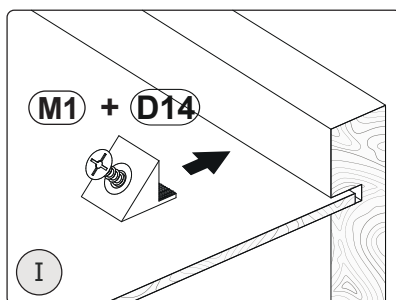
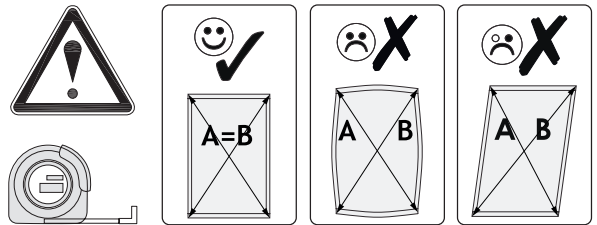
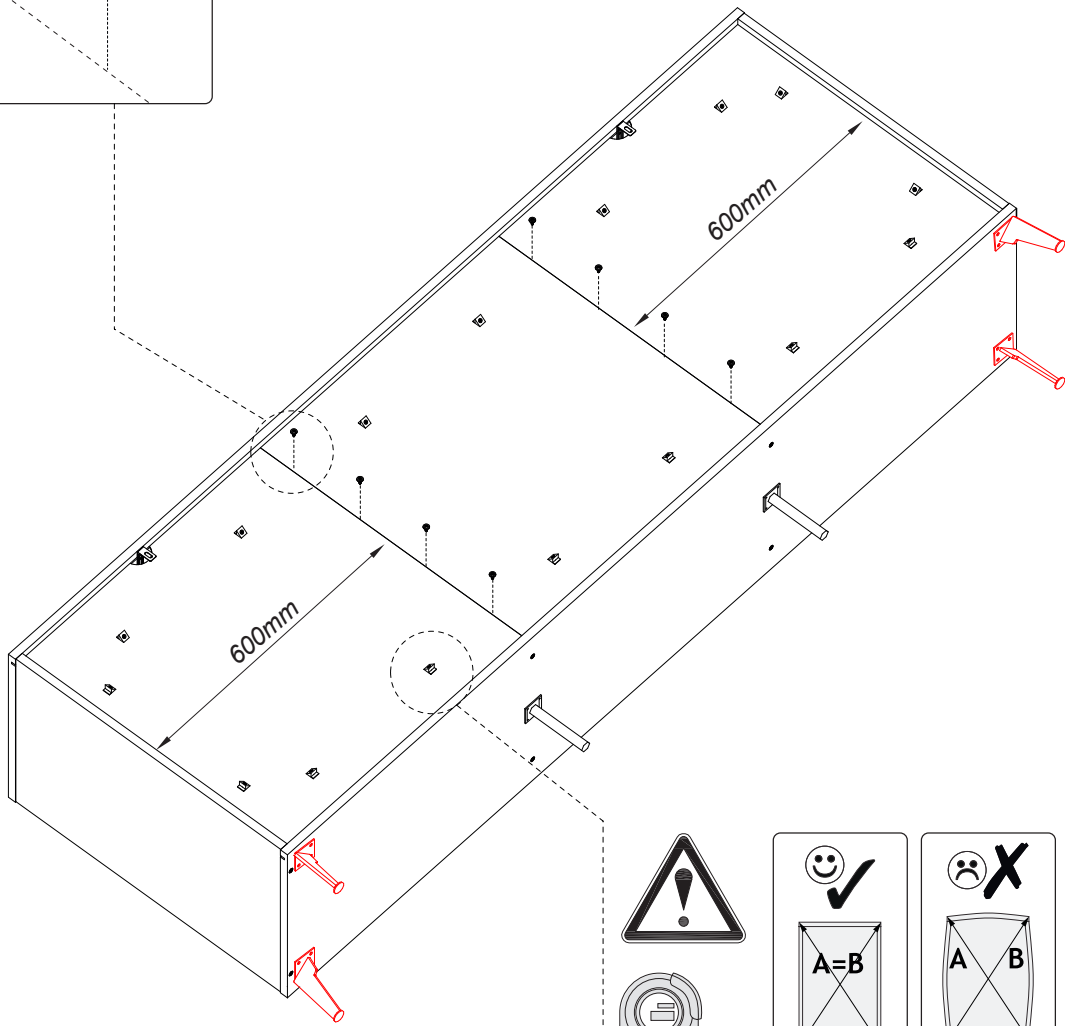
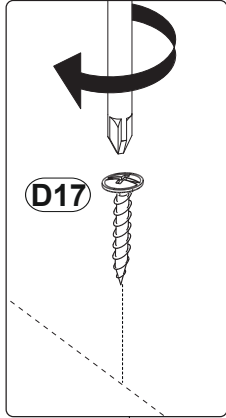

10

N1



x8

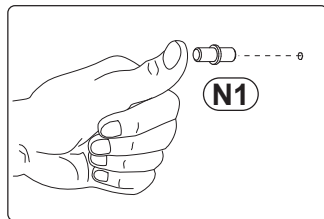
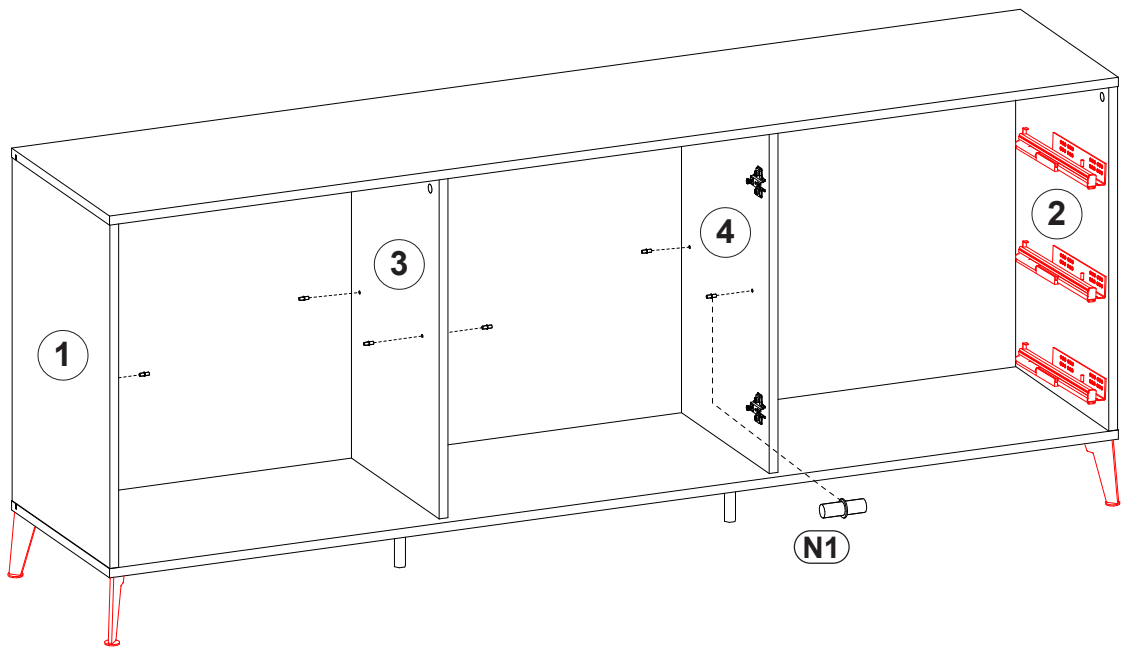

# 11

**E2**

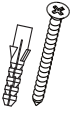

8x50



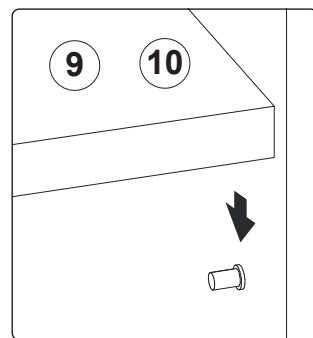
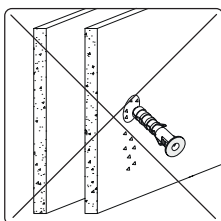
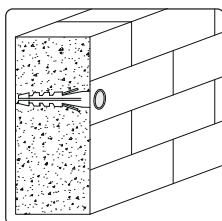
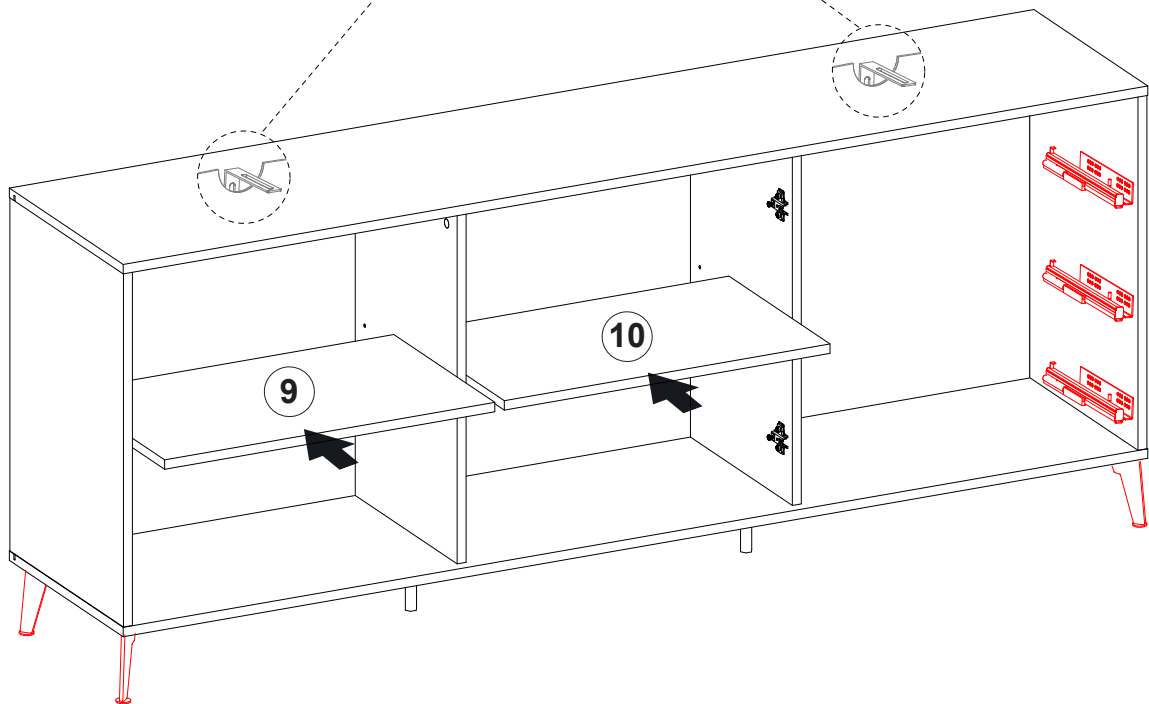
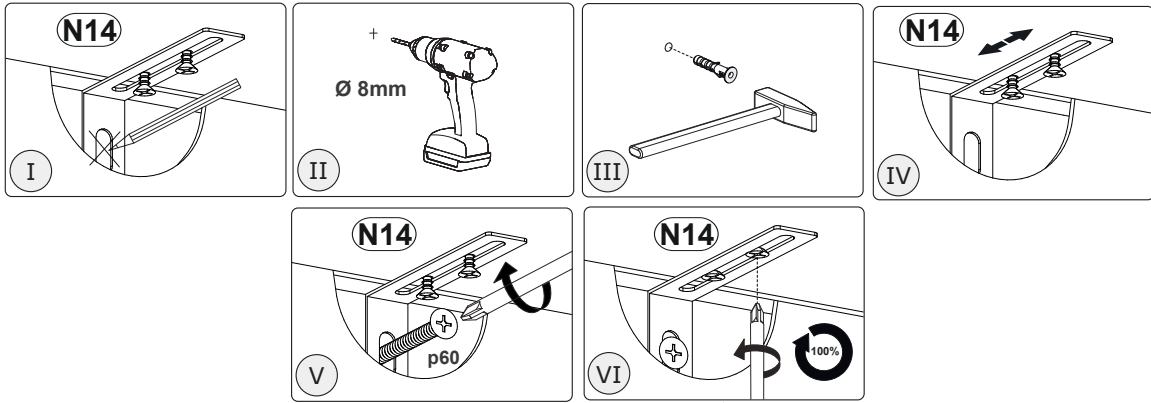

**x2**

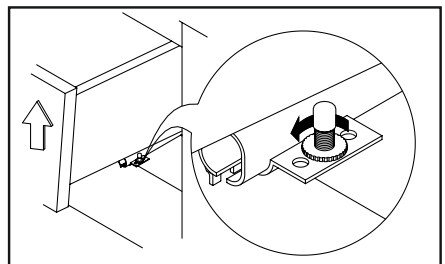
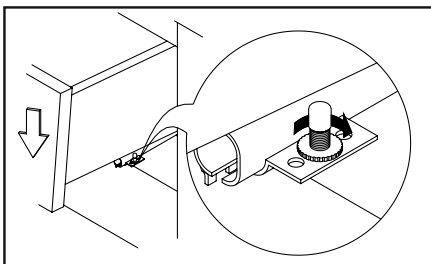
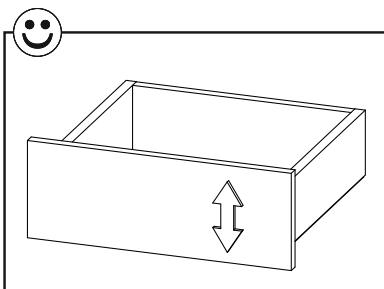
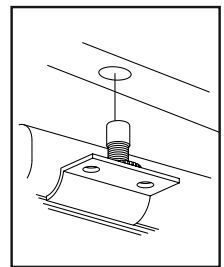
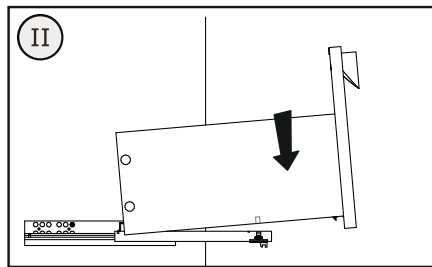
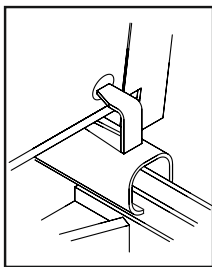
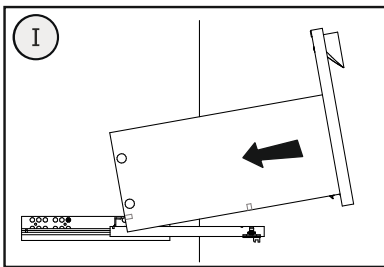
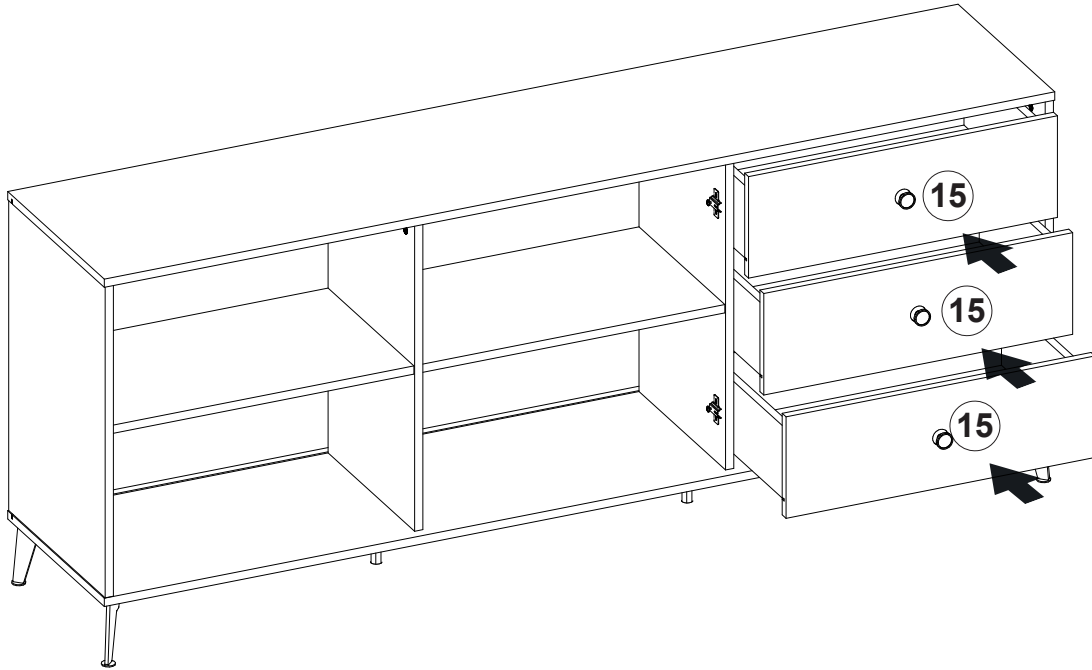

# 12

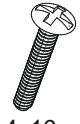

# 13

<b>D11</b>	<b>L14</b>	<b>D19</b>	<b>J16</b>	<b>J8</b>
				
3,5x15		4x16		
<b>x8</b>	<b>x2</b>	<b>x2</b>	<b>x2</b>	<b>x2</b>

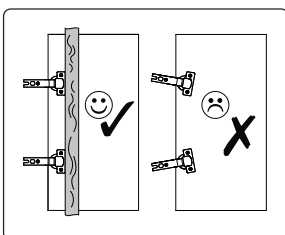
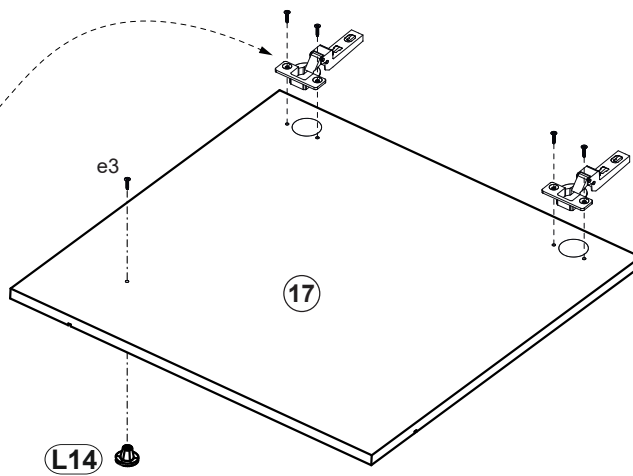
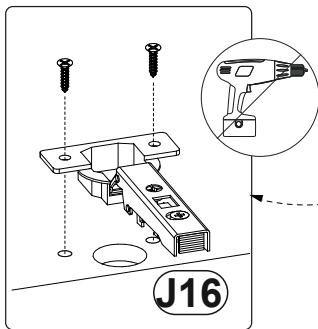
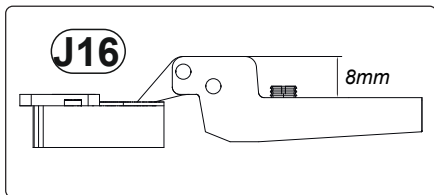
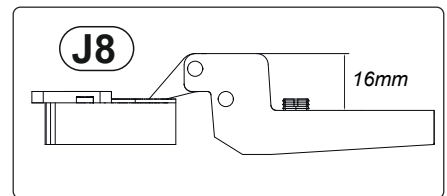
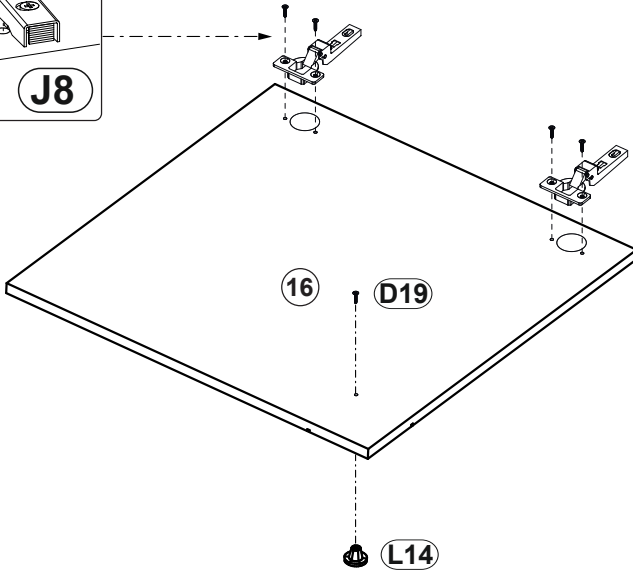
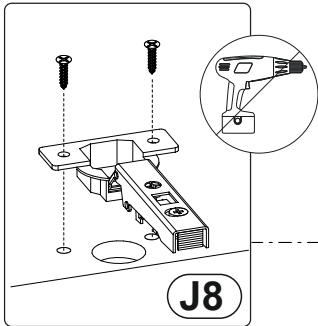

# 14

